



US010593263B2

(12) **United States Patent**
Azizi et al.

(10) **Patent No.:** **US 10,593,263 B2**
(45) **Date of Patent:** ***Mar. 17, 2020**

(54) **PIXEL CIRCUITS FOR AMOLED DISPLAYS**

(71) Applicant: **Ignis Innovation Inc.**, Waterloo (CA)

(72) Inventors: **Yaser Azizi**, Waterloo (CA);
Gholamreza Chaji, Waterloo (CA)

(73) Assignee: **Ignis Innovation Inc.**, Waterloo (CA)

(*) Notice: Subject to any disclaimer, the term of this patent is extended or adjusted under 35 U.S.C. 154(b) by 0 days.

This patent is subject to a terminal disclaimer.

(21) Appl. No.: **15/888,451**

(22) Filed: **Feb. 5, 2018**

(65) **Prior Publication Data**

US 2018/0158411 A1 Jun. 7, 2018

Related U.S. Application Data

(63) Continuation of application No. 15/494,951, filed on Apr. 24, 2017, now Pat. No. 9,922,596, which is a (Continued)

(51) **Int. Cl.**

G09G 3/3233 (2016.01)

H05B 33/08 (2020.01)

G09G 3/3258 (2016.01)

(52) **U.S. Cl.**

CPC **G09G 3/3233** (2013.01); **G09G 3/3258** (2013.01); **H05B 33/0848** (2013.01); (Continued)

(58) **Field of Classification Search**

CPC G09G 3/3291; G09G 3/3233; G09G 3/006; G09G 2320/029; G09G 2320/0233; G09G 2320/045

See application file for complete search history.

(56) **References Cited**

U.S. PATENT DOCUMENTS

3,506,851 A 4/1970 Polkinghorn

3,750,987 A 8/1973 Gobel

(Continued)

FOREIGN PATENT DOCUMENTS

AU 729652 6/1997

AU 764896 12/2001

(Continued)

OTHER PUBLICATIONS

Ahnood et al.: "Effect of threshold voltage instability on field effect mobility in thin film transistors deduced from constant current measurements"; dated Aug. 2009.

(Continued)

Primary Examiner — Antonio Xavier

(74) *Attorney, Agent, or Firm* — Stratford Managers Corporation

(57) **ABSTRACT**

The OLED voltage of a selected pixel is extracted from the pixel produced when the pixel is programmed so that the pixel current is a function of the OLED voltage. One method for extracting the OLED voltage is to first program the pixel in a way that the current is not a function of OLED voltage, and then in a way that the current is a function of OLED voltage. During the latter stage, the programming voltage is changed so that the pixel current is the same as the pixel current when the pixel was programmed in a way that the current was not a function of OLED voltage. The difference in the two programming voltages is then used to extract the OLED voltage.

6 Claims, 5 Drawing Sheets

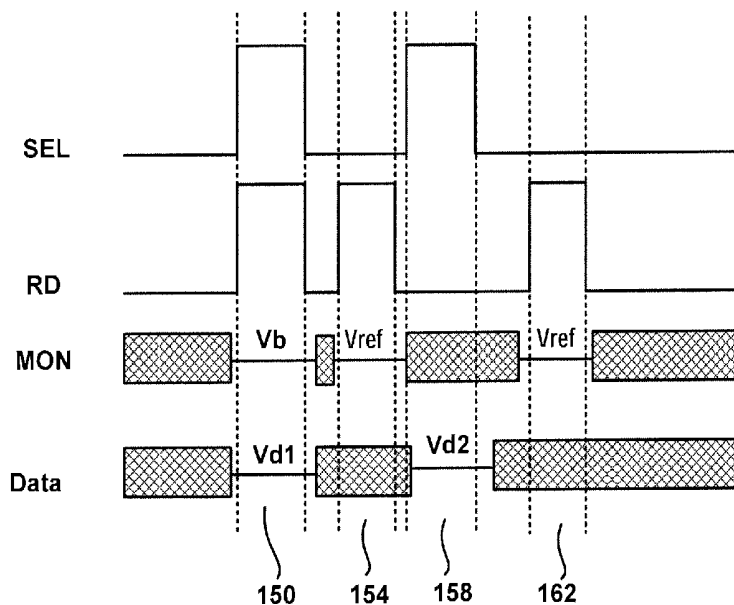

Related U.S. Application Data

continuation of application No. 15/133,318, filed on Apr. 20, 2016, now Pat. No. 9,659,527, which is a continuation of application No. 13/789,978, filed on Mar. 8, 2013, now Pat. No. 9,351,368.

(52) **U.S. Cl.**

CPC G09G 2300/0819 (2013.01); G09G 2300/0842 (2013.01); G09G 2320/0295 (2013.01); G09G 2320/045 (2013.01); G09G 2320/048 (2013.01); G09G 2320/0693 (2013.01); G09G 2320/10 (2013.01)

(56)

References Cited

U.S. PATENT DOCUMENTS

3,774,055	A	11/1973	Bapat	6,501,098	B2	12/2002	Yamazaki
4,090,096	A	5/1978	Nagami	6,501,466	B1	12/2002	Yamagashi
4,354,162	A	10/1982	Wright	6,522,315	B2	2/2003	Ozawa
4,996,523	A	2/1991	Bell	6,535,185	B2	3/2003	Kim
5,134,387	A	7/1992	Smith	6,542,138	B1	4/2003	Shannon
5,153,420	A	10/1992	Hack	6,559,839	B1	5/2003	Ueno
5,170,158	A	12/1992	Shinya	6,580,408	B1	6/2003	Bae
5,204,661	A	4/1993	Hack	6,583,398	B2	6/2003	Harkin
5,266,515	A	11/1993	Robb	6,618,030	B2	9/2003	Kane
5,278,542	A	1/1994	Smith	6,639,244	B1	10/2003	Yamazaki
5,408,267	A	4/1995	Main	6,680,580	B1	1/2004	Sung
5,498,880	A	3/1996	Lee	6,686,699	B2	2/2004	Yumoto
5,572,444	A	11/1996	Lentz	6,690,000	B1	2/2004	Muramatsu
5,589,847	A	12/1996	Lewis	6,693,610	B2	2/2004	Shannon
5,619,033	A	4/1997	Weisfield	6,694,248	B2	2/2004	Smith
5,648,276	A	7/1997	Hara	6,697,057	B2	2/2004	Koyama
5,670,973	A	9/1997	Bassetti	6,724,151	B2	4/2004	Yoo
5,691,783	A	11/1997	Numao	6,734,636	B2	5/2004	Sanford
5,701,505	A	12/1997	Yamashita	6,753,655	B2	6/2004	Shih
5,714,968	A	2/1998	Ikeda	6,753,834	B2	6/2004	Mikami
5,744,824	A	4/1998	Kousai	6,756,741	B2	6/2004	Li
5,745,660	A	4/1998	Kolpatzlik	6,756,958	B2	6/2004	Furuhashi
5,748,160	A	5/1998	Shieh	6,777,888	B2	8/2004	Kondo
5,758,129	A	5/1998	Gray	6,781,567	B2	8/2004	Kimura
5,835,376	A	11/1998	Smith	6,788,231	B1	9/2004	Hsueh
5,870,071	A	2/1999	Kawahata	6,809,706	B2	10/2004	Shimoda
5,874,803	A	2/1999	Garbuzov	6,828,950	B2	12/2004	Koyama
5,880,582	A	3/1999	Sawada	6,858,991	B2	2/2005	Miyazawa
5,903,248	A	5/1999	Irwin	6,859,193	B1	2/2005	Yumoto
5,917,280	A	6/1999	Burrows	6,876,346	B2	4/2005	Anzai
5,949,398	A	9/1999	Kim	6,900,485	B2	5/2005	Lee
5,952,789	A	9/1999	Stewart	6,903,734	B2	6/2005	Eu
5,990,629	A	11/1999	Yamada	6,911,960	B1	6/2005	Yokoyama
6,023,259	A	2/2000	Howard	6,911,964	B2	6/2005	Lee
6,069,365	A	5/2000	Chow	6,914,448	B2	7/2005	Jinno
6,091,203	A	7/2000	Kawashima	6,919,871	B2	7/2005	Kwon
6,097,360	A	8/2000	Holloman	6,924,602	B2	8/2005	Komiya
6,100,868	A	8/2000	Lee	6,937,220	B2	8/2005	Kitaura
6,144,222	A	11/2000	Ho	6,940,214	B1	9/2005	Komiya
6,229,506	B1	5/2001	Dawson	6,954,194	B2	10/2005	Matsumoto
6,229,508	B1	5/2001	Kane	6,970,149	B2	11/2005	Chung
6,246,180	B1	6/2001	Nishigaki	6,975,142	B2	12/2005	Azami
6,252,248	B1	6/2001	Sano	6,975,332	B2	12/2005	Arnold
6,268,841	B1	7/2001	Cairns	6,995,519	B2	2/2006	Arnold
6,288,696	B1	9/2001	Holloman	7,027,015	B2	4/2006	Booth, Jr.
6,307,322	B1	10/2001	Dawson	7,034,793	B2	4/2006	Sekiya
6,310,962	B1	10/2001	Chung	7,038,392	B2	5/2006	Libsch
6,323,631	B1	11/2001	Juang	7,057,588	B2	6/2006	Asano
6,333,729	B1	12/2001	Ha	7,061,451	B2	6/2006	Kimura
6,384,804	B1	5/2002	Dodabalapur	7,071,932	B2	7/2006	Libsch
6,388,653	B1	5/2002	Goto	7,106,285	B2	9/2006	Naugler
6,392,617	B1	5/2002	Gleason	7,112,820	B2	9/2006	Chang
6,396,469	B1	5/2002	Miwa	7,113,864	B2	9/2006	Smith
6,414,661	B1	7/2002	Shen	7,122,835	B1	10/2006	Ikeda
6,417,825	B1	7/2002	Stewart	7,129,914	B2	10/2006	Knapp
6,430,496	B1	8/2002	Smith	7,164,417	B2	1/2007	Cok
6,433,488	B1	8/2002	Bu	7,224,332	B2	5/2007	Cok
6,473,065	B1	10/2002	Fan	7,248,236	B2	7/2007	Nathan
6,475,845	B2	11/2002	Kimura	7,259,737	B2	8/2007	Ono
				7,262,753	B2	8/2007	Tanghe
				7,274,363	B2	9/2007	Ishizuka
				7,310,092	B2	12/2007	Imamura
				7,315,295	B2	1/2008	Kimura
				7,317,434	B2	1/2008	Lan
				7,321,348	B2	1/2008	Cok
				7,327,357	B2	2/2008	Jeong
				7,333,077	B2	2/2008	Koyama
				7,343,243	B2	3/2008	Smith
				7,414,600	B2	8/2008	Nathan
				7,466,166	B2	12/2008	Date
				7,495,501	B2	2/2009	Iwabuchi
				7,502,000	B2	3/2009	Yuki
				7,515,124	B2	4/2009	Yaguma
				7,535,449	B2	5/2009	Miyazawa
				7,554,512	B2	6/2009	Steer
				7,569,849	B2	8/2009	Nathan
				7,595,776	B2	9/2009	Hashimoto
				7,604,718	B2	10/2009	Zhang
				7,609,239	B2	10/2009	Chang

(56)

References Cited

U.S. PATENT DOCUMENTS

7,612,745 B2	11/2009	Yumoto	2003/0020413 A1	1/2003	Oomura
7,619,594 B2	11/2009	Hu	2003/0030603 A1	2/2003	Shimoda
7,619,597 B2	11/2009	Nathan	2003/0062524 A1	4/2003	Kimura
7,639,211 B2	12/2009	Miyazawa	2003/0062844 A1	4/2003	Miyazawa
7,683,899 B2	3/2010	Hirakata	2003/0076048 A1	4/2003	Rutherford
7,688,289 B2	3/2010	Abe	2003/0090445 A1	5/2003	Chen
7,760,162 B2	7/2010	Miyazawa	2003/0090447 A1	5/2003	Kimura
7,808,008 B2	10/2010	Miyake	2003/0090481 A1	5/2003	Kimura
7,859,520 B2	12/2010	Kimura	2003/0095087 A1	5/2003	Libsch
7,889,159 B2	2/2011	Nathan	2003/0098829 A1	5/2003	Chen
7,903,127 B2	3/2011	Kwon	2003/0107560 A1	6/2003	Yumoto
7,920,116 B2	4/2011	Woo	2003/0107561 A1	6/2003	Uchino
7,944,414 B2	5/2011	Shirasaki	2003/0111966 A1	6/2003	Mikami
7,978,170 B2	7/2011	Park	2003/0112205 A1	6/2003	Yamada
7,989,392 B2	8/2011	Crockett	2003/0112208 A1	6/2003	Okabe
7,995,008 B2	8/2011	Miwa	2003/0117348 A1	6/2003	Knapp
8,040,303 B2	10/2011	Kim et al.	2003/0122474 A1	7/2003	Lee
8,063,852 B2	11/2011	Kwak	2003/0122747 A1	7/2003	Shannon
8,102,343 B2	1/2012	Yatabe	2003/0128199 A1	7/2003	Kimura
8,144,081 B2	3/2012	Miyazawa	2003/0151569 A1	8/2003	Lee
8,159,007 B2	4/2012	Barna	2003/0156104 A1	8/2003	Morita
8,237,746 B2	8/2012	Betts-LaCroix	2003/0169241 A1	9/2003	LeChevalier
8,242,979 B2	8/2012	Anzai	2003/0169247 A1	9/2003	Kawabe
8,253,665 B2	8/2012	Nathan	2003/0174152 A1	9/2003	Noguchi
8,283,967 B2	10/2012	Chaji	2003/0179626 A1	9/2003	Sanford
8,319,712 B2	11/2012	Nathan	2003/0185438 A1	10/2003	Osawa
8,564,513 B2	10/2013	Nathan	2003/0189535 A1	10/2003	Matsumoto
8,872,739 B2	10/2014	Kimura	2003/0197663 A1	10/2003	Lee
9,351,368 B2 *	5/2016	Azizi H05B 33/0848	2003/0214465 A1	11/2003	Kimura
9,430,958 B2	8/2016	Chaji	2003/0227262 A1	12/2003	Kwon
9,466,240 B2	10/2016	Jaffari	2003/0230141 A1	12/2003	Gilmour
9,472,138 B2	10/2016	Nathan	2003/0230980 A1	12/2003	Forrest
9,659,527 B2	5/2017	Williams	2004/0004589 A1	1/2004	Shih
9,685,114 B2	7/2017	Chaji	2004/0032382 A1	2/2004	Cok
9,697,771 B2	7/2017	Azizi	2004/0041750 A1	3/2004	Abe
9,721,505 B2	8/2017	Chaji	2004/0066357 A1	4/2004	Kawasaki
9,741,292 B2	8/2017	Nathan	2004/0070557 A1	4/2004	Asano
9,747,834 B2	8/2017	Chaji	2004/0070558 A1	4/2004	Cok
RE46,561 E	9/2017	Chaji	2004/0090186 A1	5/2004	Yoshida
9,922,596 B2 *	3/2018	Azizi H05B 33/0848	2004/0095338 A1	5/2004	Takashi
2001/0002703 A1	6/2001	Koyama	2004/0129933 A1	7/2004	Nathan
2001/0009283 A1	7/2001	Arao	2004/0130516 A1	7/2004	Nathan
2001/0024186 A1	9/2001	Kane	2004/0135749 A1	7/2004	Kondakov
2001/0026257 A1	10/2001	Kimura	2004/0145547 A1	7/2004	Oh
2001/0030323 A1	10/2001	Ikeda	2004/0150595 A1	8/2004	Kasai
2001/0035863 A1	11/2001	Kimura	2004/0155841 A1	8/2004	Kasai
2001/0040541 A1	11/2001	Yoneda	2004/0160516 A1	8/2004	Ford
2001/0043173 A1	11/2001	Troutman	2004/0171619 A1	9/2004	Barkoczy
2001/0045929 A1	11/2001	Prache	2004/0174349 A1	9/2004	Libsch
2001/0052940 A1	12/2001	Hagihara	2004/0174354 A1	9/2004	Ono
2002/0000576 A1	1/2002	Inukai	2004/0183759 A1	9/2004	Stevenson
2002/0011796 A1	1/2002	Koyama	2004/0189627 A1	9/2004	Shirasaki
2002/0011799 A1	1/2002	Kimura	2004/0196275 A1	10/2004	Hattori
2002/0012057 A1	1/2002	Kimura	2004/0227697 A1	11/2004	Mori
2002/0030190 A1	3/2002	Ohtani	2004/0239696 A1	12/2004	Okabe
2002/0047565 A1	4/2002	Nara	2004/0251844 A1	12/2004	Hashido
2002/0052086 A1	5/2002	Maeda	2004/0252085 A1	12/2004	Miyagawa
2002/0080108 A1	6/2002	Wang	2004/0252089 A1	12/2004	Ono
2002/0084463 A1	7/2002	Sanford	2004/0256617 A1	12/2004	Yamada
2002/0101172 A1	8/2002	Bu	2004/0257353 A1	12/2004	Imamura
2002/0117722 A1	8/2002	Osada	2004/0257355 A1	12/2004	Naugler
2002/0140712 A1	10/2002	Ouchi	2004/0263437 A1	12/2004	Hattori
2002/0158587 A1	10/2002	Komiya	2005/0007357 A1	1/2005	Yamashita
2002/0158666 A1	10/2002	Azami	2005/0052379 A1	3/2005	Waterman
2002/0158823 A1	10/2002	Zavracky	2005/0057459 A1	3/2005	Miyazawa
2002/0171613 A1	11/2002	Goto	2005/0067970 A1	3/2005	Libsch
2002/0181275 A1	12/2002	Yamazaki	2005/0067971 A1	3/2005	Kane
2002/0186214 A1	12/2002	Siwinski	2005/0083270 A1	4/2005	Miyazawa
2002/0190971 A1	12/2002	Nakamura	2005/0110420 A1	5/2005	Arnold
2002/0195967 A1	12/2002	Kim	2005/0110727 A1	5/2005	Shin
2002/0195968 A1	12/2002	Sanford	2005/0123193 A1	6/2005	Lamberg
2002/0196213 A1	12/2002	Akimoto	2005/0140600 A1	6/2005	Kim
2003/0001828 A1	1/2003	Asano	2005/0140610 A1	6/2005	Smith
2003/0001858 A1	1/2003	Jack	2005/0145891 A1	7/2005	Abe
2003/0016190 A1	1/2003	Kondo	2005/0156831 A1	7/2005	Yamazaki
			2005/0168416 A1	8/2005	Hashimoto
			2005/0206590 A1	9/2005	Sasaki
			2005/0212787 A1	9/2005	Noguchi
			2005/0219188 A1	10/2005	Kawabe

(56)

References Cited

U.S. PATENT DOCUMENTS

2005/0243037 A1 11/2005 Eom
 2005/0248515 A1 11/2005 Naugler
 2005/0258867 A1 11/2005 Miyazawa
 2005/0285822 A1 12/2005 Reddy
 2005/0285825 A1 12/2005 Eom
 2006/0012311 A1 1/2006 Ogawa
 2006/0022305 A1 2/2006 Yamashita
 2006/0038750 A1 2/2006 Inoue
 2006/0038758 A1 2/2006 Routley
 2006/0038762 A1 2/2006 Chou
 2006/0066533 A1 3/2006 Sato
 2006/0077077 A1 4/2006 Kwon
 2006/0077134 A1 4/2006 Hector
 2006/0077194 A1 4/2006 Jeong
 2006/0092185 A1 5/2006 Jo
 2006/0114196 A1 6/2006 Shin
 2006/0125408 A1 6/2006 Nathan
 2006/0125740 A1 6/2006 Shirasaki
 2006/0139253 A1 6/2006 Choi
 2006/0145964 A1 7/2006 Park
 2006/0158402 A1* 7/2006 Nathan G09G 3/3233
 345/82
 2006/0191178 A1 8/2006 Sempel
 2006/0208971 A1 9/2006 Deane
 2006/0209012 A1 9/2006 Hagood, IV
 2006/0214888 A1 9/2006 Schneider
 2006/0221009 A1 10/2006 Miwa
 2006/0227082 A1 10/2006 Ogata
 2006/0232522 A1 10/2006 Roy
 2006/0244391 A1 11/2006 Shishido
 2006/0244697 A1 11/2006 Lee
 2006/0261841 A1 11/2006 Fish
 2006/0279478 A1 12/2006 Ikegami
 2006/0290614 A1 12/2006 Nathan
 2007/0001939 A1 1/2007 Hashimoto
 2007/0001945 A1 1/2007 Yoshida
 2007/0008251 A1 1/2007 Kohno
 2007/0008297 A1 1/2007 Bassetti
 2007/0035489 A1 2/2007 Lee
 2007/0035707 A1 2/2007 Margulis
 2007/0040773 A1 2/2007 Lee
 2007/0040782 A1 2/2007 Woo
 2007/0057873 A1 3/2007 Uchino
 2007/0057874 A1 3/2007 Le Roy
 2007/0063932 A1 3/2007 Nathan
 2007/0075957 A1 4/2007 Chen
 2007/0080908 A1 4/2007 Nathan
 2007/0085801 A1 4/2007 Park
 2007/0109232 A1 5/2007 Yamamoto
 2007/0128583 A1 6/2007 Miyazawa
 2007/0164941 A1 7/2007 Park
 2007/0182671 A1 8/2007 Nathan
 2007/0236430 A1 10/2007 Fish
 2007/0236440 A1 10/2007 Wacyk
 2007/0241999 A1 10/2007 Lin
 2007/0242008 A1 10/2007 Cummings
 2008/0001544 A1 1/2008 Murakami
 2008/0043044 A1 2/2008 Woo
 2008/0048951 A1 2/2008 Naugler
 2008/0055134 A1 3/2008 Li
 2008/0062106 A1 3/2008 Tseng
 2008/0074360 A1 3/2008 Lu
 2008/0088549 A1* 4/2008 Nathan G09G 3/3233
 345/80
 2008/0094426 A1 4/2008 Kimpe
 2008/0111766 A1 5/2008 Uchino
 2008/0122819 A1 5/2008 Cho
 2008/0129906 A1 6/2008 Lin
 2008/0198103 A1 8/2008 Toyomura
 2008/0219232 A1 9/2008 Heubel et al.
 2008/0228562 A1 9/2008 Smith
 2008/0231625 A1 9/2008 Minami
 2008/0231641 A1 9/2008 Miyashita
 2008/0265786 A1 10/2008 Koyama
 2008/0290805 A1 11/2008 Yamada

2009/0009459 A1 1/2009 Miyashita
 2009/0015532 A1 1/2009 Katayama
 2009/0058789 A1 3/2009 Hung
 2009/0121988 A1 5/2009 Amo
 2009/0146926 A1 6/2009 Sung
 2009/0153448 A1 6/2009 Tomida
 2009/0153459 A9 6/2009 Han
 2009/0174628 A1 7/2009 Wang
 2009/0201230 A1 8/2009 Smith
 2009/0201281 A1 8/2009 Routley
 2009/0206764 A1 8/2009 Schemmann
 2009/0225011 A1 9/2009 Choi
 2009/0244046 A1 10/2009 Seto
 2009/0251486 A1 10/2009 Sakakibara
 2009/0278777 A1 11/2009 Wang
 2009/0289964 A1 11/2009 Miyachi
 2009/0295423 A1* 12/2009 Levey G09G 3/006
 324/760.01
 2010/0026725 A1 2/2010 Smith
 2010/0033469 A1 2/2010 Nathan
 2010/0039451 A1 2/2010 Jung
 2010/0039453 A1 2/2010 Nathan
 2010/0045646 A1* 2/2010 Kishi G09G 3/3233
 345/211
 2010/0079419 A1 4/2010 Shibusawa
 2010/0134475 A1* 6/2010 Ogura G09G 3/3291
 345/213
 2010/0141564 A1 6/2010 Choi
 2010/0149223 A1 6/2010 Betts-LaCroix
 2010/0207920 A1 8/2010 Chaji
 2010/0225634 A1 9/2010 Levey
 2010/0251295 A1 9/2010 Amento
 2010/0269889 A1 10/2010 Reinhold
 2010/0277400 A1 11/2010 Jeong
 2010/0315319 A1 12/2010 Cok
 2010/0315449 A1* 12/2010 Chaji G09G 3/3208
 345/690
 2011/0050741 A1 3/2011 Jeong
 2011/0063197 A1 3/2011 Chung
 2011/0069089 A1 3/2011 Kopf
 2011/0074762 A1* 3/2011 Shirasaki G09G 3/3225
 345/211
 2011/0084993 A1 4/2011 Kawabe
 2011/0109350 A1 5/2011 Chaji
 2011/0169805 A1 7/2011 Katsunori
 2011/0191042 A1* 8/2011 Chaji G09G 3/32
 702/64
 2011/0205221 A1* 8/2011 Lin G09G 3/2092
 345/213
 2012/0026146 A1 2/2012 Kim
 2012/0169793 A1 7/2012 Nathan
 2012/0293478 A1* 11/2012 Chaji G09G 3/3258
 345/212
 2012/0299976 A1 11/2012 Chen
 2012/0299978 A1* 11/2012 Chaji G09G 3/3291
 345/690
 2014/0267215 A1 9/2014 Soni

FOREIGN PATENT DOCUMENTS

CA 1 294 034 1/1992
 CA 2 249 592 7/1998
 CA 2 303 302 3/1999
 CA 2 368 386 9/1999
 CA 2 242 720 1/2000
 CA 2 354 018 6/2000
 CA 2 432 530 7/2002
 CA 2 436 451 8/2002
 CA 2 507 276 8/2002
 CA 2 463 653 1/2004
 CA 2 498 136 3/2004
 CA 2 522 396 11/2004
 CA 2 438 363 2/2005
 CA 2 443 206 3/2005
 CA 2 519 097 3/2005
 CA 2 472 671 12/2005
 CA 2 523 841 1/2006
 CA 2 567 076 1/2006

(56)

References Cited

OTHER PUBLICATIONS

FOREIGN PATENT DOCUMENTS

- | | | |
|----|-------------------|---------|
| CA | 2 495 726 | 7/2006 |
| CA | 2 557 713 | 11/2006 |
| CA | 2 526 782 C | 8/2007 |
| CA | 2 651 893 | 11/2007 |
| CA | 2 672 590 | 10/2009 |
| CN | 1180418 A | 4/1998 |
| CN | 1588521 | 3/2005 |
| CN | 1601594 A | 3/2005 |
| CN | 1886774 | 12/2006 |
| CN | 101395653 | 3/2009 |
| CN | 101908316 A | 12/2010 |
| CN | 103562989 A | 2/2014 |
| DE | 202006007613 | 9/2006 |
| EP | 0 478 186 | 4/1992 |
| EP | 0811866 A1 | 12/1997 |
| EP | 1 028 471 A | 8/2000 |
| EP | 1 130 565 A1 | 9/2001 |
| EP | 1 194 013 | 4/2002 |
| EP | 1 321 922 | 6/2003 |
| EP | 1 335 430 A1 | 8/2003 |
| EP | 1 381 019 | 1/2004 |
| EP | 1 429 312 A | 6/2004 |
| EP | 1 439 520 A2 | 7/2004 |
| EP | 1 465 143 A | 10/2004 |
| EP | 1 473 689 A | 11/2004 |
| EP | 1 517 290 A2 | 3/2005 |
| EP | 1 521 203 A2 | 4/2005 |
| GB | 2 399 935 | 9/2004 |
| GB | 2 460 018 | 11/2009 |
| JP | 09 090405 | 4/1997 |
| JP | 10-254410 | 9/1998 |
| JP | 11 231805 | 8/1999 |
| JP | 2002-278513 | 9/2002 |
| JP | 2003-076331 | 3/2003 |
| JP | 2003-099000 | 4/2003 |
| JP | 2003-173165 | 6/2003 |
| JP | 2003-186439 | 7/2003 |
| JP | 2003-195809 | 7/2003 |
| JP | 2003-271095 | 9/2003 |
| JP | 2003-308046 | 10/2003 |
| JP | 2004-054188 | 2/2004 |
| JP | 2004-226960 | 8/2004 |
| JP | 2005-004147 | 1/2005 |
| JP | 2005-099715 | 4/2005 |
| JP | 2005-258326 | 9/2005 |
| JP | 2005-338819 | 12/2005 |
| TW | 569173 | 1/2004 |
| TW | 200526065 | 8/2005 |
| TW | 1239501 | 9/2005 |
| WO | WO 98/11554 | 3/1998 |
| WO | WO 99/48079 | 9/1999 |
| WO | WO 01/27910 A1 | 4/2001 |
| WO | WO 02/067327 A | 8/2002 |
| WO | WO 03/034389 | 4/2003 |
| WO | WO 03/063124 | 7/2003 |
| WO | WO 03/075256 | 9/2003 |
| WO | WO 2004/003877 | 1/2004 |
| WO | WO 2004/015668 A1 | 2/2004 |
| WO | WO 2004/034364 | 4/2004 |
| WO | WO 2005/022498 | 3/2005 |
| WO | WO 2005/055185 | 6/2005 |
| WO | WO 2005/055186 A1 | 6/2005 |
| WO | WO 2005/069267 | 7/2005 |
| WO | WO 2005/122121 | 12/2005 |
| WO | WO 2006/063448 | 6/2006 |
| WO | WO 2006/128069 | 11/2006 |
| WO | WO 2007/079572 | 7/2007 |
| WO | WO 2008/057369 | 5/2008 |
| WO | WO 2009/059028 | 5/2009 |
| WO | WO 2009/127065 | 10/2009 |
| WO | WO 2010/066030 | 6/2010 |
| WO | WO 2010/120733 | 10/2010 |
- Alexander et al.: "Pixel circuits and drive schemes for glass and elastic AMOLED displays"; dated Jul. 2005 (9 pages).
- Alexander et al.: "Unique Electrical Measurement Technology for Compensation Inspection and Process Diagnostics of AMOLED HDTV"; dated May 2010 (4 pages).
- Ashtiani et al.: "AMOLED Pixel Circuit With Electronic Compensation of Luminance Degradation"; dated Mar. 2007 (4 pages).
- Chaji et al.: "A Current-Mode Comparator for Digital Calibration of Amorphous Silicon AMOLED Displays"; dated Jul. 2008 (5 pages).
- Chaji et al.: "A fast settling current driver based on the CCII for AMOLED displays"; dated Dec. 2009 (6 pages).
- Chaji et al.: "A Low-Cost Stable Amorphous Silicon AMOLED Display with Full V~T- and V~O~L~E~D Shift Compensation"; dated May 2007 (4 pages).
- Chaji et al.: "A low-power driving scheme for a-Si:H active-matrix organic light-emitting diode displays"; dated Jun. 2005 (4 pages).
- Chaji et al.: "A low-power high-performance digital circuit for deep submicron technologies"; dated Jun. 2005 (4 pages).
- Chaji et al.: "A novel a-Si:H AMOLED pixel circuit based on short-term stress stability of a-Si:H TFTs"; dated Oct. 2005 (3 pages).
- Chaji et al.: "A Novel Driving Scheme and Pixel Circuit for AMOLED Displays"; dated Jun. 2006 (4 pages).
- Chaji et al.: "A novel driving scheme for high-resolution large-area a-Si:H AMOLED displays"; dated Aug. 2005 (4 pages).
- Chaji et al.: "A Stable Voltage-Programmed Pixel Circuit for a-Si:H AMOLED Displays"; dated Dec. 2006 (12 pages).
- Chaji et al.: "A Sub- μ A fast-settling current-programmed pixel circuit for AMOLED displays"; dated Sep. 2007.
- Chaji et al.: "An Enhanced and Simplified Optical Feedback Pixel Circuit for AMOLED Displays"; dated Oct. 2006.
- Chaji et al.: "Compensation technique for DC and transient instability of thin film transistor circuits for large-area devices"; dated Aug. 2008.
- Chaji et al.: "Driving scheme for stable operation of 2-TFT a-Si AMOLED pixel"; dated Apr. 2005 (2 pages).
- Chaji et al.: "Dynamic-effect compensating technique for stable a-Si:H AMOLED displays"; dated Aug. 2005 (4 pages).
- Chaji et al.: "Electrical Compensation of OLED Luminance Degradation"; dated Dec. 2007 (3 pages).
- Chaji et al.: "eUTDPS: a design study of a new VLIW-based DSP architecture"; dated May 2003 (4 pages).
- Chaji et al.: "Fast and Offset-Leakage Insensitive Current-Mode Line Driver for Active Matrix Displays and Sensors"; dated Feb. 2009 (8 pages).
- Chaji et al.: "High Speed Low Power Adder Design With a New Logic Style: Pseudo Dynamic Logic (SDL)"; dated Oct. 2001 (4 pages).
- Chaji et al.: "High-precision fast current source for large-area current-programmed a-Si flat panels"; dated Sep. 2006 (4 pages).
- Chaji et al.: "Low-Cost AMOLED Television with IGNIS Compensating Technology"; dated May 2008 (4 pages).
- Chaji et al.: "Low-Cost Stable a-Si:H AMOLED Display for Portable Applications"; dated Jun. 2006 (4 pages).
- Chaji et al.: "Low-Power Low-Cost Voltage-Programmed a-Si:H AMOLED Display"; dated Jun. 2008 (5 pages).
- Chaji et al.: "Merged phototransistor pixel with enhanced near infrared response and flicker noise reduction for biomolecular imaging"; dated Nov. 2008 (3 pages).
- Chaji et al.: "Parallel Addressing Scheme for Voltage-Programmed Active-Matrix OLED Displays"; dated May 2007 (6 pages).
- Chaji et al.: "Pseudo dynamic logic (SDL): a high-speed and low-power dynamic logic family"; dated 2002 (4 pages).
- Chaji et al.: "Stable a-Si:H circuits based on short-term stress stability of amorphous silicon thin film transistors"; dated May 2006 (4 pages).
- Chaji et al.: "Stable Pixel Circuit for Small-Area High-Resolution a-Si:H AMOLED Displays"; dated Oct. 2008 (6 pages).
- Chaji et al.: "Stable RGBW AMOLED display with OLED degradation compensation using electrical feedback"; dated Feb. 2010 (2 pages).

(56)

References Cited

OTHER PUBLICATIONS

- Chaji et al.: "Thin-Film Transistor Integration for Biomedical Imaging and AMOLED Displays"; dated May 2008 (177 pages). Chapter 3: Color Spaces" Keith Jack: "Video Demystified: "A Handbook for the Digital Engineer" 2001 Referex ORD-0000-00-00 USA EP040425529 ISBN: 1-878707-56-6 pp. 32-33. Chapter 8: Alternative Flat Panel Display 1-25 Technologies; Willem den Boer: "Active Matrix Liquid Crystal Display: Fundamentals and Applications" 2005 Referex ORD-0000-00-00 U.K.; XP040426102 ISBN: 0-7506-7813-5 pp. 206-209 p. 208. European Patent Search Report Application No. 12 15 6251.6 European Patent Office dated May 30 2012 (7 pages). European Patent Office Communication Application No. 05 82 1114 dated Jan. 11, 2013 (9 pages). European Patent Office Communication with Supplemental European Search Report for EP Application No. 07 70 1644.2 dated Aug. 18, 2009 (12 pages). European Search Report Application No. 10 83 4294.0-1903 dated Apr. 8, 2013 (9 pages). European Search Report Application No. EP 05 80 7905 dated Apr. 2, 2009 (5 pages). European Search Report Application No. EP 05 82 1114 dated Mar. 27 2009 (2 pages). European Search Report Application No. EP 07 70 1644 dated Aug. 5, 2009. European Search Report Application No. EP 10 17 5764 dated Oct. 18, 2010 (2 pages). European Search Report Application No. EP 10 82 9593.2 European Patent Office dated May 17, 2013 (7 pages). European Search Report Application No. EP 12 15 6251.6 European Patent Office dated Oct. 12, 2012 (18 pages). European Search Report Application No. EP. 11 175 225.9 dated Nov. 4, 2011 (9 pages). European Supplementary Search Report Application No. EP 09 80 2309 dated May 8, 2011 (14 pages). European Supplementary Search Report Application No. EP 09 83 1339.8 dated Mar. 26, 2012 (11 pages). Extended European Search Report Application No. EP 06 75 2777.0 dated Dec. 6, 2010 (21 pages). Extended European Search Report Application No. EP 09 73 2338.0 dated May 24, 2011 (8 pages). Extended European Search Report Application No. EP 11 17 5223, 4 dated Nov. 8, 2011 (8 pages). Extended European Search Report Application No. EP 12 17 4465.0 European Patent Office dated Sep. 7, 2012 (9 pages). Fan et al. "LTPS TFT Pixel Circuit Compensation for TFT Threshold Voltage Shift and IR-Drop on the Power Line for Amoled Displays" 5 pages copyright 2012. Goh et al. "A New a-Si:H Thin-Film Transistor Pixel Circuit for Active-Matrix Organic Light-Emitting Diodes" IEEE Electron Device Letters vol. 24 No. 9 Sep. 2003 pp. 583-585. International Search Report Application No. PCT/CA2005/001844 dated Mar. 28, 2006 (2 pages). International Search Report Application No. PCT/CA2006/000941 dated Oct. 3, 2006 (2 pages). International Search Report Application No. PCT/CA2007/000013 dated May 7, 2007. International Search Report Application No. PCT/CA2009/001049 dated Dec. 7, 2009 (4 pages). International Search Report Application No. PCT/CA2009/001769 dated Apr. 8, 2010. International Search Report Application No. PCT/IB2010/002898 Canadian Intellectual Property Office dated Jul. 28, 2009 (5 pages). International Search Report Application No. PCT/IB2010/055481 dated Apr. 7, 2011 (3 pages). International Search Report Application No. PCT/IB2011/051103 dated Jul. 8, 2011 3 pages. International Search Report Application No. PCT/IB2012/052651 5 pages dated Sep. 11, 2012. International Searching Authority Written Opinion Application No. PCT/IB2010/055481 dated Apr. 7, 2011 (6 pages). International Searching Authority Written Opinion Application No. PCT/IB2012/052651 6 pages dated Sep. 11, 2012. International Searching Authority Written Opinion Application No. PCT/IB2011/051103 dated Jul. 8, 2011 6 pages. International Searching Authority Written Opinion Application No. PCT/IB2010/002898 Canadian Intellectual Property Office dated Mar. 30, 2011 (8 pages). International Searching Authority Written Opinion Application No. PCT/CA2009/001769 dated Apr. 8, 2010 (8 pages). Jafarabadiashtiani et al.: "A New Driving Method for a-Si AMOLED Displays Based on Voltage Feedback"; dated May 2005 (4 pages). Lee et al.: "Ambipolar Thin-Film Transistors Fabricated by PECVD Nanocrystalline Silicon"; dated May 2006 (6 pages). Ma e y et al.: "Organic Light-Emitting Diode/Thin Film Transistor Integration for foldable Displays" Conference record of the 1997 International display research conference and international workshops on LCD technology and emissive technology. Toronto Sep. 15-19, 1997 (6 pages). Matsueda y et al.: "35.1: 2.5-in. AMOLED with Integrated 6-bit Gamma Compensated Digital Data Driver"; dated May 2004 (4 pages). Nathan et al. "Amorphous Silicon Thin Film Transistor Circuit Integration for Organic LED Displays on Glass and Plastic" IEEE Journal of Solid-State Circuits vol. 39 No. 9 Sep. 2004 pp. 1477-1486. Nathan et al.: "Backplane Requirements for Active Matrix Organic Light Emitting Diode Displays"; dated Sep. 2006 (16 pages). Nathan et al.: "Call for papers second international workshop on compact thin-film transistor (TFT) modeling for circuit simulation"; dated Sep. 2009 (1 page). Nathan et al.: "Driving schemes for a-Si and LTPS AMOLED displays"; dated Dec. 2005 (11 pages). Nathan et al.: "Invited Paper: a -Si for AMOLED—Meeting the Performance and Cost Demands of Display Applications (Cell Phone to HDTV)"; dated Jun. 2006 (4 pages). Nathan et al.: "Thin film imaging technology on glass and plastic"; dated Oct. 31-Nov. 2, 2000 (4 pages). Ono et al. "Shared Pixel Compensation Circuit for AM-OLED Displays" Proceedings of the 9th Asian Symposium on Information Display (ASID) pp. 462-465 New Delhi dated Oct. 8-12, 2006 (4 pages). Philipp: "Charge transfer sensing" Sensor Review vol. 19 No. 2 Dec. 31, 1999 (Dec. 31, 1999) 10 pages. Rafati et al.: "Comparison of a 17 b multiplier in Dual-rail domino and in Dual-rail D L (D L) logic styles"; dated 2002 (4 pages). Safavian et al.: "Three-TFT image sensor for real-time digital X-ray imaging"; dated Feb. 2, 2006 (2 pages). Safavian et al.: "3-TFT active pixel sensor with correlated double sampling readout circuit for real-time medical x-ray imaging"; dated Jun. 2006 (4 pages). Safavian et al.: "A novel current scaling active pixel sensor with correlated double sampling readout circuit for real time medical x-ray imaging"; dated May 2007 (7 pages). Safavian et al.: "A novel hybrid active-passive pixel with correlated double sampling CMOS readout circuit for medical x-ray imaging"; dated May 2008 (4 pages). Safavian et al.: "Self-compensated a-Si:H detector with current-mode readout circuit for digital X-ray fluoroscopy"; dated Aug. 2005 (4 pages). Safavian et al.: "TFT active image sensor with current-mode readout circuit for digital x-ray fluoroscopy [5969D-82]"; dated Sep. 2005 (9 pages). Smith, Lindsay I., "A tutorial on Principal Components Analysis," dated Feb. 26, 2001 (27 pages). Stewart M. et al. "Polysilicon TFT technology for active matrix OLED displays" IEEE transactions on electron devices vol. 48 No. May 5, 2001 (7 pages). Vygranenko et al.: "Stability of indium-oxide thin-film transistors by reactive ion beam assisted deposition"; dated Feb. 2009.

(56)

References Cited

OTHER PUBLICATIONS

Wang et al.: "Indium oxides by reactive ion beam assisted evaporation: From material study to device application," dated Mar. 2009 (6 pages).

Yi He et al. "Current-Source a-Si:H Thin Film Transistor Circuit for Active-Matrix Organic Light-Emitting Displays" IEEE Electron Device Letters vol. 21 No. 12 Dec. 2000 pp. 590-592.

International Search Report Application No. PCT/IB2013/059074, dated Dec. 18, 2013 (5 pages).

International Searching Authority Written Opinion Application No. PCT/IB2013/059074, dated Dec. 18, 2013 (8 pages).

Extended European Search Report Application No. EP 15173106.4 dated Oct. 15, 2013 (8 pages).

International Search Report Application No. PCT/IB2017/050170, dated May 5, 2017 (3 pages).

International Searching Authority Written Opinion Application No. PCT/IB2017/050170, dated May 5, 2017 (4 pages).

* cited by examiner

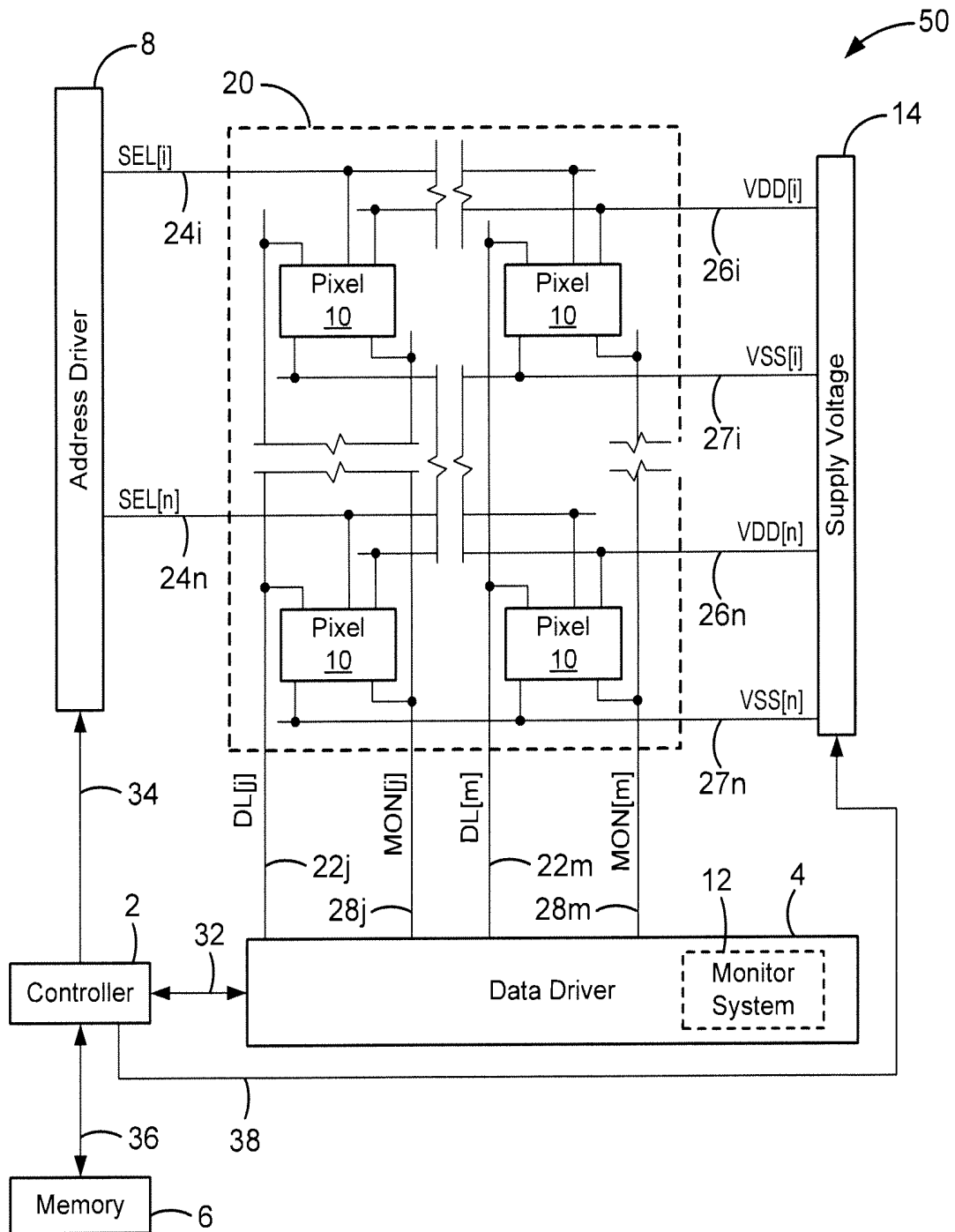

FIG. 1

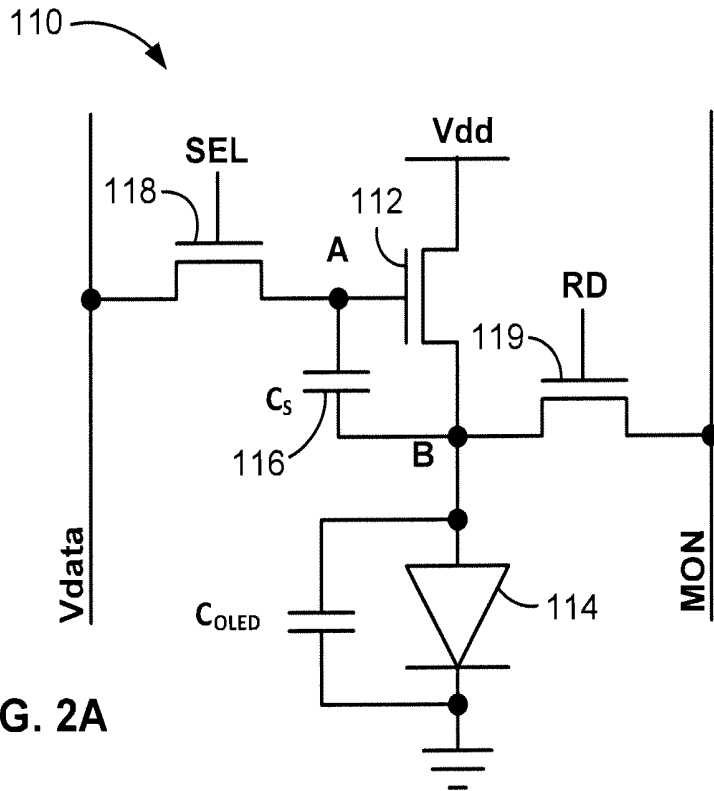

FIG. 2A

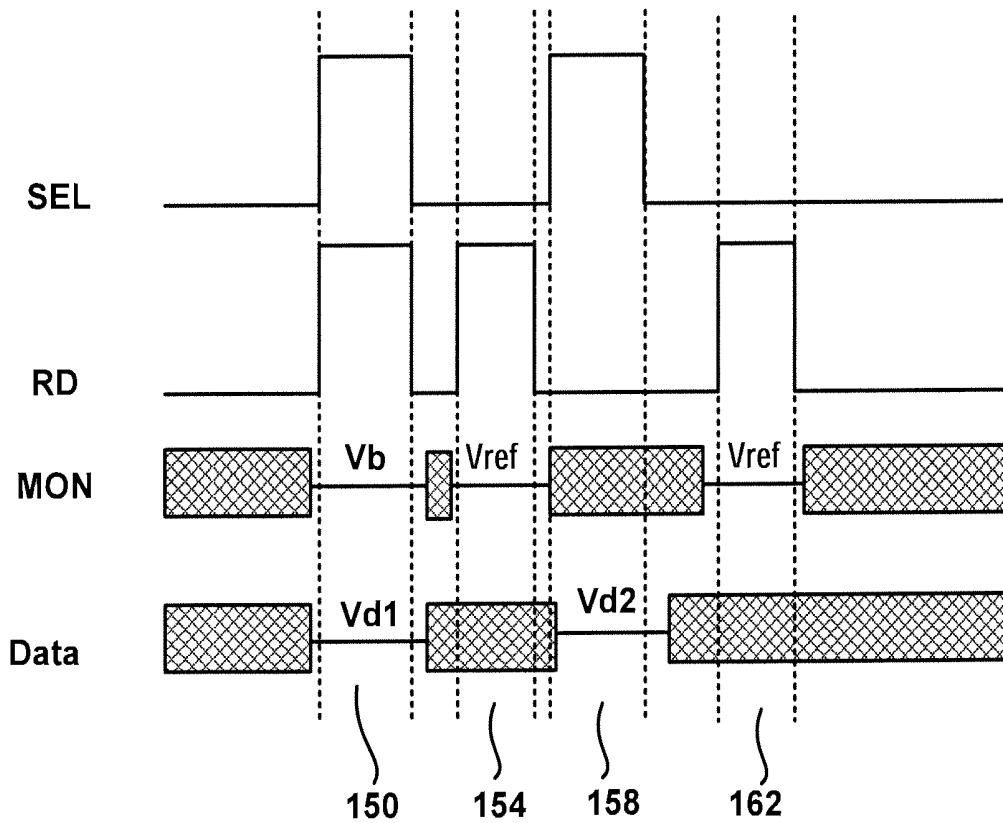

FIG. 2B

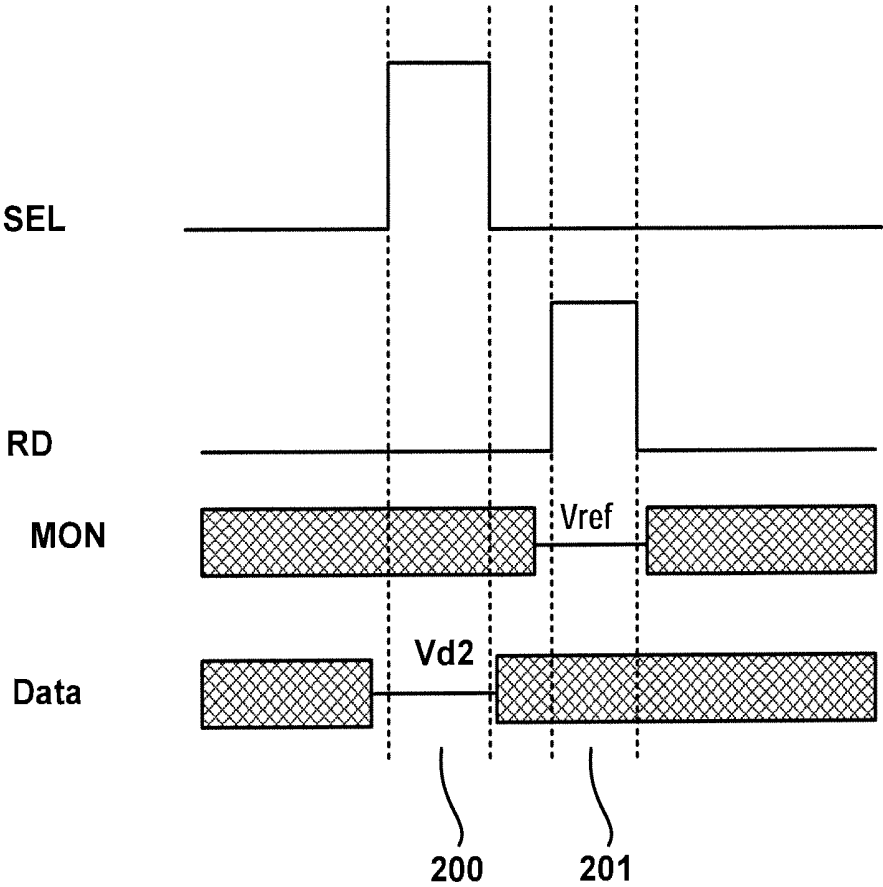

FIG. 2C

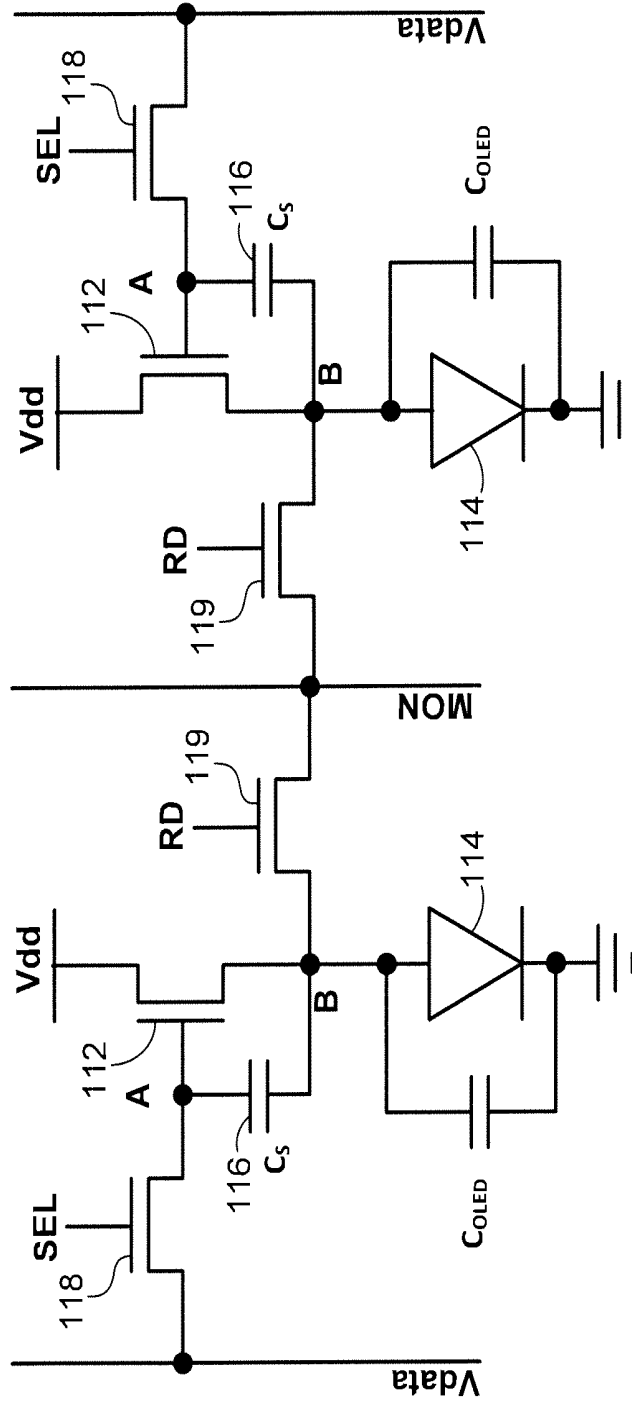

FIG. 3

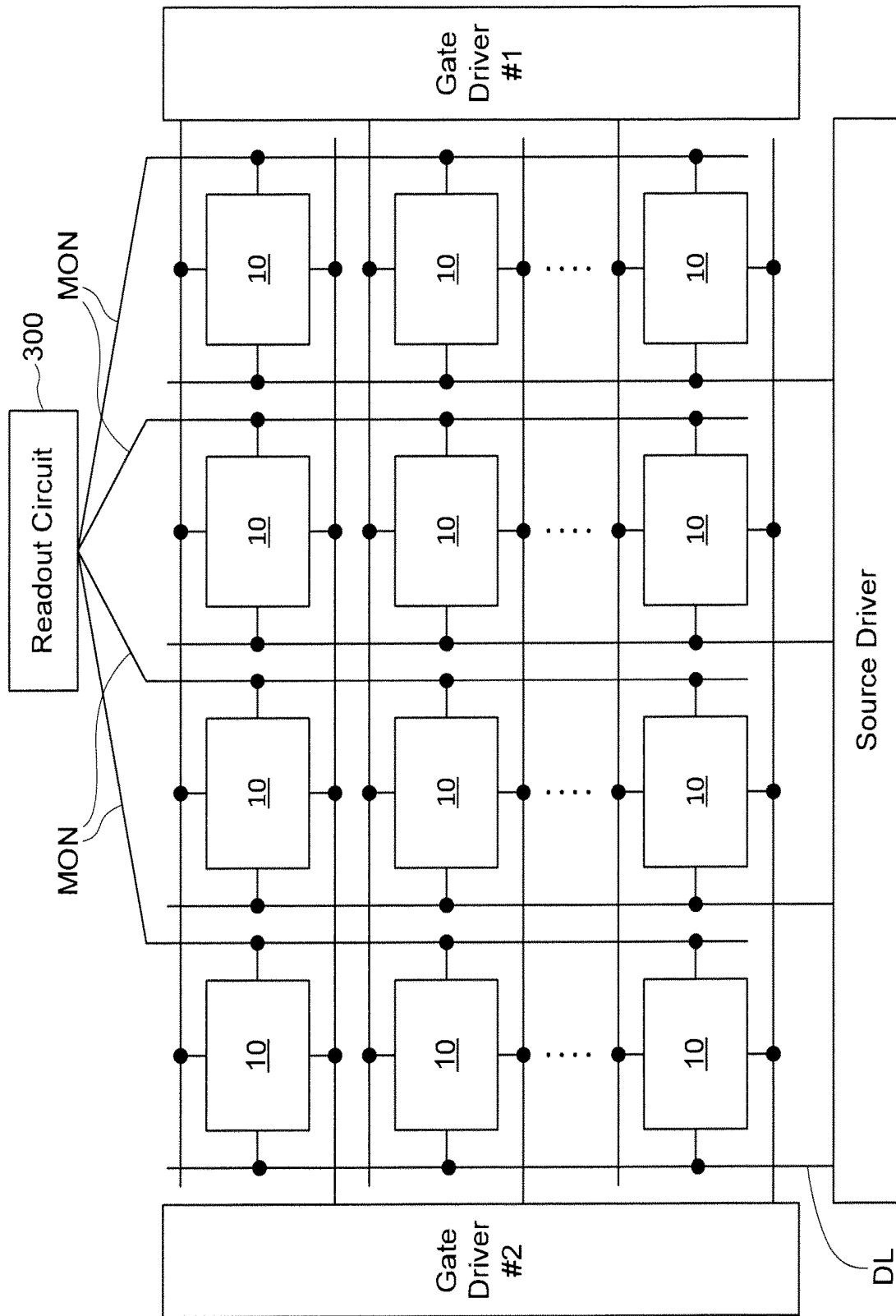

FIG. 4

PIXEL CIRCUITS FOR AMOLED DISPLAYS

CROSS REFERENCE TO RELATED APPLICATIONS

This application is a continuation of U.S. patent application Ser. No. 15/494,951, filed Apr. 24, 2017, now allowed, which is a continuation of U.S. patent application Ser. No. 15/133,318, filed Apr. 20, 2016, now U.S. Pat. No. 9,659,527, which is a continuation of and claims the benefit of U.S. patent application Ser. No. 13/789,978, filed Mar. 8, 2013, now U.S. Pat. No. 9,351,368, both of which are hereby incorporated by reference herein in their entireties.

FIELD OF THE INVENTION

The present disclosure generally relates to circuits for use in displays, and methods of driving, calibrating, and programming displays, particularly displays such as active matrix organic light emitting diode displays.

BACKGROUND

Displays can be created from an array of light emitting devices each controlled by individual circuits (i.e., pixel circuits) having transistors for selectively controlling the circuits to be programmed with display information and to emit light according to the display information. Thin film transistors ("TFTs") fabricated on a substrate can be incorporated into such displays. TFTs tend to demonstrate non-uniform behavior across display panels and over time as the displays age. Compensation techniques can be applied to such displays to achieve image uniformity across the displays and to account for degradation in the displays as the displays age.

Some schemes for providing compensation to displays to account for variations across the display panel and over time utilize monitoring systems to measure time dependent parameters associated with the aging (i.e., degradation) of the pixel circuits. The measured information can then be used to inform subsequent programming of the pixel circuits so as to ensure that any measured degradation is accounted for by adjustments made to the programming. Such monitored pixel circuits may require the use of additional transistors and/or lines to selectively couple the pixel circuits to the monitoring systems and provide for reading out information. The incorporation of additional transistors and/or lines may undesirably decrease pixel-pitch (i.e., "pixel density").

SUMMARY

In accordance with one embodiment, the OLED voltage of a selected pixel is extracted from the pixel produced when the pixel is programmed so that the pixel current is a function of the OLED voltage. One method for extracting the OLED voltage is to first program the pixel in a way that the current is not a function of OLED voltage, and then in a way that the current is a function of OLED voltage. During the latter stage, the programming voltage is changed so that the pixel current is the same as the pixel current when the pixel was programmed in a way that the current was not a function of OLED voltage. The difference in the two programming voltages is then used to extract the OLED voltage.

Another method for extracting the OLED voltage is to measure the difference between the current of the pixel when

it is programmed with a fixed voltage in both methods (being affected by OLED voltage and not being affected by OLED voltage). This measured difference and the current-voltage characteristics of the pixel are then used to extract the OLED voltage.

A further method for extracting the shift in the OLED voltage is to program the pixel for a given current at time zero (before usage) in a way that the pixel current is a function of OLED voltage, and save the programming voltage. To extract the OLED voltage shift after some usage time, the pixel is programmed for the given current as was done at time zero. To get the same current as time zero, the programming voltage needs to change. The difference in the two programming voltages is then used to extract the shift in the OLED voltage. Here one needs to remove the effect of TFT aging from the second programming voltage first; this is done by programming the pixel without OLED effect for a given current at time zero and after usage. The difference in the programming voltages in this case is the TFT aging, which is subtracted from the calculated difference in the aforementioned case.

In one implementation, the current effective voltage V_{OLED} of a light-emitting device in a selected pixel is determined by supplying a programming voltage to the drive transistor in the selected pixel to supply a first current to the light-emitting device (the first current being independent of the effective voltage V_{OLED} of the light-emitting device), measuring the first current, supplying a second programming voltage to the drive transistor in the selected pixel to supply a second current to the light-emitting device, the second current being a function of the current effective voltage V_{OLED} of the light-emitting device, measuring the second current and comparing the first and second current measurements, adjusting the second programming voltage to make the second current substantially the same as the first current, and extracting the value of the current effective voltage V_{OLED} of the light-emitting device from the difference between the first and second programming voltages.

In another implementation, the current effective voltage V_{OLED} of a light-emitting device in a selected pixel is determined by supplying a first programming voltage to the drive transistor in the selected pixel to supply a first current to the light-emitting device in the selected pixel (the first current being independent of the effective voltage V_{OLED} of the light-emitting device), measuring the first current, supplying a second programming voltage to the drive transistor in the selected pixel to supply a second current to the light-emitting device in the selected pixel (the second current being a function of the current effective voltage V_{OLED} of the light-emitting device), measuring the second current, and extracting the value of the current effective voltage V_{OLED} of the light-emitting device from the difference between the first and second current measurements.

In a modified implementation, the current effective voltage V_{OLED} of a light-emitting device in a selected pixel is determined by supplying a first programming voltage to the drive transistor in the selected pixel to supply a predetermined current to the light-emitting device at a first time (the first current being a function of the effective voltage V_{OLED} of the light-emitting device), supplying a second programming voltage to the drive transistor in the selected pixel to supply the predetermined current to the light-emitting device at a second time following substantial usage of the display, and extracting the value of the current effective voltage V_{OLED} of the light-emitting device from the difference between the first and second programming voltages.

In another modified implementation, the current effective voltage V_{OLED} of a light-emitting device in a selected pixel is determined by supplying a predetermined programming voltage to the drive transistor in the selected pixel to supply a first current to the light-emitting device (the first current being independent of the effective voltage V_{OLED} of the light-emitting device), measuring the first current, supplying the predetermined programming voltage to the drive transistor in the selected pixel to supply a second current to the light-emitting device (the second current being a function of the current effective voltage V_{OLED} of the light-emitting device), measuring the second current, and extracting the value of the current effective voltage V_{OLED} of the light-emitting device from the difference between the first and second currents and current-voltage characteristics of the selected pixel.

In a preferred implementation, a system is provided for controlling an array of pixels in a display in which each pixel includes a light-emitting device. Each pixel includes a pixel circuit that comprises the light-emitting device, which emits light when supplied with a voltage V_{OLED} ; a drive transistor for driving current through the light-emitting device according to a driving voltage across the drive transistor during an emission cycle, the drive transistor having a gate, a source and a drain and characterized by a threshold voltage; and a storage capacitor coupled across the source and gate of the drive transistor for providing the driving voltage to the drive transistor. A supply voltage source is coupled to the drive transistor for supplying current to the light-emitting device via the drive transistor, the current being controlled by the driving voltage. A monitor line is coupled to a read transistor that controls the coupling of the monitor line to a first node that is common to the source side of the storage capacitor, the source of the drive transistor, and the light-emitting device. A data line is coupled to a switching transistor that controls the coupling of the data line to a second node that is common to the gate side of the storage capacitor and the gate of the drive transistor. A controller coupled to the data and monitor lines and to the switching and read transistors is adapted to:

- (1) during a first cycle, turn on the switching and read transistors while delivering a voltage V_b to the monitor line and a voltage V_{d1} to the data line, to supply the first node with a voltage that is independent of the voltage across the light-emitting device,
- (2) during a second cycle, turn on the read transistor and turn off the switching transistor while delivering a voltage V_{ref} to the monitor line, and read a first sample of the drive current at the first node via the read transistor and the monitor line,
- (3) during a third cycle, turn off the read transistor and turn on the switching transistor while delivering a voltage V_{d2} to the data line, so that the voltage at the second node is a function of V_{OLED} , and
- (4) during a fourth cycle, turn on said read transistor and turn off said switching transistor while delivering a voltage V_{ref} to said monitor line, and read a second sample the drive current at said first node via said read transistor and said monitor line. The first and second samples of the drive current are compared and, if they are different, the first through fourth cycles are repeated using an adjusted value of at least one of the voltages V_{d1} and V_{d2} , until the first and second samples are substantially the same.

The foregoing and additional aspects and embodiments of the present invention will be apparent to those of ordinary skill in the art in view of the detailed description of various

embodiments and/or aspects, which is made with reference to the drawings, a brief description of which is provided next.

BRIEF DESCRIPTION OF THE DRAWINGS

The foregoing and other advantages of the invention will become apparent upon reading the following detailed description and upon reference to the drawings.

FIG. 1 is a block diagram of an exemplary configuration of a system for driving an OLED display while monitoring the degradation of the individual pixels and providing compensation therefor.

FIG. 2A is a circuit diagram of an exemplary pixel circuit configuration.

FIG. 2B is a timing diagram of first exemplary operation cycles for the pixel shown in FIG. 2A.

FIG. 2C is a timing diagram of second exemplary operation cycles for the pixel shown in FIG. 2A.

FIG. 3 is a circuit diagram of another exemplary pixel circuit configuration.

FIG. 4 is a block diagram of a modified configuration of a system for driving an OLED display using a shared readout circuit, while monitoring the degradation of the individual pixels and providing compensation therefor.

While the invention is susceptible to various modifications and alternative forms, specific embodiments have been shown by way of example in the drawings and will be described in detail herein. It should be understood, however, that the invention is not intended to be limited to the particular forms disclosed. Rather, the invention is to cover all modifications, equivalents, and alternatives falling within the spirit and scope of the invention as defined by the appended claims.

DETAILED DESCRIPTION

FIG. 1 is a diagram of an exemplary display system 50. The display system 50 includes an address driver 8, a data driver 4, a controller 2, a memory storage 6, and display panel 20. The display panel 20 includes an array of pixels 10 arranged in rows and columns. Each of the pixels 10 is individually programmable to emit light with individually programmable luminance values. The controller 2 receives digital data indicative of information to be displayed on the display panel 20. The controller 2 sends signals 32 to the data driver 4 and scheduling signals 34 to the address driver 8 to drive the pixels 10 in the display panel 20 to display the information indicated. The plurality of pixels 10 associated with the display panel 20 thus comprise a display array ("display screen") adapted to dynamically display information according to the input digital data received by the controller 2. The display screen can display, for example, video information from a stream of video data received by the controller 2. The supply voltage 14 can provide a constant power voltage or can be an adjustable voltage supply that is controlled by signals from the controller 2. The display system 50 can also incorporate features from a current source or sink (not shown) to provide biasing currents to the pixels 10 in the display panel 20 to thereby decrease programming time for the pixels 10.

For illustrative purposes, the display system 50 in FIG. 1 is illustrated with only four pixels 10 in the display panel 20. It is understood that the display system 50 can be implemented with a display screen that includes an array of similar pixels, such as the pixels 10, and that the display screen is not limited to a particular number of rows and

columns of pixels. For example, the display system 50 can be implemented with a display screen with a number of rows and columns of pixels commonly available in displays for mobile devices, monitor-based devices, and/or projection devices.

The pixel 10 is operated by a driving circuit (“pixel circuit”) that generally includes a driving transistor and a light emitting device. Hereinafter the pixel 10 may refer to the pixel circuit. The light emitting device can optionally be an organic light emitting diode, but implementations of the present disclosure apply to pixel circuits having other electroluminescence devices, including current-driven light emitting devices. The driving transistor in the pixel 10 can optionally be an n-type or p-type amorphous silicon thin-film transistor, but implementations of the present disclosure are not limited to pixel circuits having a particular polarity of transistor or only to pixel circuits having thin-film transistors. The pixel circuit 10 can also include a storage capacitor for storing programming information and allowing the pixel circuit 10 to drive the light emitting device after being addressed. Thus, the display panel 20 can be an active matrix display array.

As illustrated in FIG. 1, the pixel 10 illustrated as the top-left pixel in the display panel 20 is coupled to a select line 24*i*, a supply line 26*i*, a data line 22*j*, and a monitor line 28*j*. A read line may also be included for controlling connections to the monitor line. In one implementation, the supply voltage 14 can also provide a second supply line to the pixel 10. For example, each pixel can be coupled to a first supply line 26 charged with V_{dd} and a second supply line 27 coupled with V_{ss}, and the pixel circuits 10 can be situated between the first and second supply lines to facilitate driving current between the two supply lines during an emission phase of the pixel circuit. The top-left pixel 10 in the display panel 20 can correspond to a pixel in the display panel in a “*i*th” row and “*j*th” column of the display panel 20. Similarly, the top-right pixel 10 in the display panel 20 represents a “*j*th” row and “*m*th” column; the bottom-left pixel 10 represents an “*n*th” row and “*j*th” column; and the bottom-right pixel 10 represents an “*n*th” row and “*m*th” column. Each of the pixels 10 is coupled to appropriate select lines (e.g., the select lines 24*i* and 24*n*), supply lines (e.g., the supply lines 26*i* and 26*n*), data lines (e.g., the data lines 22*j* and 22*m*), and monitor lines (e.g., the monitor lines 28*j* and 28*m*). It is noted that aspects of the present disclosure apply to pixels having additional connections, such as connections to additional select lines, and to pixels having fewer connections, such as pixels lacking a connection to a monitoring line.

With reference to the top-left pixel 10 shown in the display panel 20, the select line 24*i* is provided by the address driver 8, and can be utilized to enable, for example, a programming operation of the pixel 10 by activating a switch or transistor to allow the data line 22*j* to program the pixel 10. The data line 22*j* conveys programming information from the data driver 4 to the pixel 10. For example, the data line 22*j* can be utilized to apply a programming voltage or a programming current to the pixel 10 in order to program the pixel 10 to emit a desired amount of luminance. The programming voltage (or programming current) supplied by the data driver 4 via the data line 22*j* is a voltage (or current) appropriate to cause the pixel 10 to emit light with a desired amount of luminance according to the digital data received by the controller 2. The programming voltage (or programming current) can be applied to the pixel 10 during a programming operation of the pixel 10 so as to charge a storage device within the pixel 10, such as a storage capaci-

tor, thereby enabling the pixel 10 to emit light with the desired amount of luminance during an emission operation following the programming operation. For example, the storage device in the pixel 10 can be charged during a programming operation to apply a voltage to one or more of a gate or a source terminal of the driving transistor during the emission operation, thereby causing the driving transistor to convey the driving current through the light emitting device according to the voltage stored on the storage device.

Generally, in the pixel 10, the driving current that is conveyed through the light emitting device by the driving transistor during the emission operation of the pixel 10 is a current that is supplied by the first supply line 26*i* and is drained to a second supply line 27*i*. The first supply line 26*i* and the second supply line 27*i* are coupled to the voltage supply 14. The first supply line 26*i* can provide a positive supply voltage (e.g., the voltage commonly referred to in circuit design as “V_{dd}”) and the second supply line 27*i* can provide a negative supply voltage (e.g., the voltage commonly referred to in circuit design as “V_{ss}”). Implementations of the present disclosure can be realized where one or the other of the supply lines (e.g., the supply line 27*i*) is fixed at a ground voltage or at another reference voltage.

The display system 50 also includes a monitoring system 12. With reference again to the top left pixel 10 in the display panel 20, the monitor line 28*j* connects the pixel 10 to the monitoring system 12. The monitoring system 12 can be integrated with the data driver 4, or can be a separate stand-alone system. In particular, the monitoring system 12 can optionally be implemented by monitoring the current and/or voltage of the data line 22*j* during a monitoring operation of the pixel 10, and the monitor line 28*j* can be entirely omitted. Additionally, the display system 50 can be implemented without the monitoring system 12 or the monitor line 28*j*. The monitor line 28*j* allows the monitoring system 12 to measure a current or voltage associated with the pixel 10 and thereby extract information indicative of a degradation of the pixel 10. For example, the monitoring system 12 can extract, via the monitor line 28*j*, a current flowing through the driving transistor within the pixel 10 and thereby determine, based on the measured current and based on the voltages applied to the driving transistor during the measurement, a threshold voltage of the driving transistor or a shift thereof.

The monitoring system 12 can also extract an operating voltage of the light emitting device (e.g., a voltage drop across the light emitting device while the light emitting device is operating to emit light). The monitoring system 12 can then communicate signals 32 to the controller 2 and/or the memory 6 to allow the display system 50 to store the extracted degradation information in the memory 6. During subsequent programming and/or emission operations of the pixel 10, the degradation information is retrieved from the memory 6 by the controller 2 via memory signals 36, and the controller 2 then compensates for the extracted degradation information in subsequent programming and/or emission operations of the pixel 10. For example, once the degradation information is extracted, the programming information conveyed to the pixel 10 via the data line 22*j* can be appropriately adjusted during a subsequent programming operation of the pixel 10 such that the pixel 10 emits light with a desired amount of luminance that is independent of the degradation of the pixel 10. In an example, an increase in the threshold voltage of the driving transistor within the pixel 10 can be compensated for by appropriately increasing the programming voltage applied to the pixel 10.

FIG. 2A is a circuit diagram of an exemplary driving circuit for a pixel 110. The driving circuit shown in FIG. 2A is utilized to calibrate, program and drive the pixel 110 and includes a drive transistor 112 for conveying a driving current through an organic light emitting diode (“OLED”) 114. The OLED 114 emits light according to the current passing through the OLED 114, and can be replaced by any current-driven light emitting device. The OLED 114 has an inherent capacitance C_{OLED} . The pixel 110 can be utilized in the display panel 20 of the display system 50 described in connection with FIG. 1.

The driving circuit for the pixel 110 also includes a storage capacitor 116 and a switching transistor 118. The pixel 110 is coupled to a select line SEL, a voltage supply line Vdd, a data line Vdata, and a monitor line MON. The driving transistor 112 draws a current from the voltage supply line Vdd according to a gate-source voltage (V_{gs}) across the gate and source terminals of the drive transistor 112. For example, in a saturation mode of the drive transistor 112, the current passing through the drive transistor 112 can be given by $I_{ds} = \beta(V_{gs} - V_t)^2$, where β is a parameter that depends on device characteristics of the drive transistor 112, I_{ds} is the current from the drain terminal to the source terminal of the drive transistor 112, and V_t is the threshold voltage of the drive transistor 112.

In the pixel 110, the storage capacitor 116 is coupled across the gate and source terminals of the drive transistor 112. The storage capacitor 116 has a first terminal, which is referred to for convenience as a gate-side terminal, and a second terminal, which is referred to for convenience as a source-side terminal. The gate-side terminal of the storage capacitor 116 is electrically coupled to the gate terminal of the drive transistor 112. The source-side terminal 116s of the storage capacitor 116 is electrically coupled to the source terminal of the drive transistor 112. Thus, the gate-source voltage V_{gs} of the drive transistor 112 is also the voltage charged on the storage capacitor 116. As will be explained further below, the storage capacitor 116 can thereby maintain a driving voltage across the drive transistor 112 during an emission phase of the pixel 110.

The drain terminal of the drive transistor 112 is connected to the voltage supply line Vdd, and the source terminal of the drive transistor 112 is connected to (1) the anode terminal of the OLED 114 and (2) a monitor line MON via a read transistor 119. A cathode terminal of the OLED 114 can be connected to ground or can optionally be connected to a second voltage supply line, such as the supply line Vss shown in FIG. 1. Thus, the OLED 114 is connected in series with the current path of the drive transistor 112. The OLED 114 emits light according to the magnitude of the current passing through the OLED 114, once a voltage drop across the anode and cathode terminals of the OLED achieves an operating voltage (V_{OLED}) of the OLED 114. That is, when the difference between the voltage on the anode terminal and the voltage on the cathode terminal is greater than the operating voltage V_{OLED} , the OLED 114 turns on and emits light. When the anode-to-cathode voltage is less than V_{OLED} , current does not pass through the OLED 114.

The switching transistor 118 is operated according to the select line SEL (e.g., when the voltage on the select line SEL is at a high level, the switching transistor 118 is turned on, and when the voltage SEL is at a low level, the switching transistor is turned off). When turned on, the switching transistor 118 electrically couples node A (the gate terminal of the driving transistor 112 and the gate-side terminal of the storage capacitor 116) to the data line Vdata.

The read transistor 119 is operated according to the read line RD (e.g., when the voltage on the read line RD is at a high level, the read transistor 119 is turned on, and when the voltage RD is at a low level, the read transistor 119 is turned off). When turned on, the read transistor 119 electrically couples node B (the source terminal of the driving transistor 112, the source-side terminal of the storage capacitor 116, and the anode of the OLED 114) to the monitor line MON.

FIG. 2B is a timing diagram of exemplary operation cycles for the pixel 110 shown in FIG. 2A. During a first cycle 150, both the SEL line and the RD line are high, so the corresponding transistors 118 and 119 are turned on. The switching transistor 118 applies a voltage Vd1, which is at a level sufficient to turn on the drive transistor 112, from the data line Vdata to node A. The read transistor 119 applies a monitor-line voltage Vb, which is at a level that turns the OLED 114 off, from the monitor line MON to node B. As a result, the gate-source voltage V_{gs} is independent of V_{OLED} ($V_{d1} - V_b - V_{ds3}$, where V_{ds3} is the voltage drop across the read transistor 119). The SEL and RD lines go low at the end of the cycle 150, turning off the transistors 118 and 119.

During the second cycle 154, the SEL line is low to turn off the switching transistor 118, and the drive transistor 112 is turned on by the charge on the capacitor 116 at node A. The voltage on the read line RD goes high to turn on the read transistor 119 and thereby permit a first sample of the drive transistor current to be taken via the monitor line MON, while the OLED 114 is off. The voltage on the monitor line MON is Vref, which may be at the same level as the voltage Vb in the previous cycle.

During the third cycle 158, the voltage on the select line SEL is high to turn on the switching transistor 118, and the voltage on the read line RD is low to turn off the read transistor 119. Thus, the gate of the drive transistor 112 is charged to the voltage Vd2 of the data line Vdata, and the source of the drive transistor 112 is set to V_{OLED} by the OLED 114. Consequently, the gate-source voltage V_{gs} of the drive transistor 112 is a function of V_{OLED} ($V_{gs} = V_{d2} - V_{OLED}$).

During the fourth cycle 162, the voltage on the select line SEL is low to turn off the switching transistor, and the drive transistor 112 is turned on by the charge on the capacitor 116 at node A. The voltage on the read line RD is high to turn on the read transistor 119, and a second sample of the current of the drive transistor 112 is taken via the monitor line MON.

If the first and second samples of the drive current are not the same, the voltage Vd2 on the Vdata line is adjusted, the programming voltage Vd2 is changed, and the sampling and adjustment operations are repeated until the second sample of the drive current is the same as the first sample. When the two samples of the drive current are the same, the two gate-source voltages should also be the same, which means that:

$$\begin{aligned} V_{OLED} &= V_{d2} - V_{gs} \\ &= V_{d2} - (V_{d1} - V_b - V_{ds3}) \\ &= V_{d2} - V_{d1} + V_b + V_{ds3}. \end{aligned}$$

After some operation time (t), the change in V_{OLED} between time 0 and time t is $\Delta V_{OLED} = V_{OLED}(t) - V_{OLED}(0) = V_{d2}(t) - V_{d2}(0)$. Thus, the difference between the two programming voltages $V_{d2}(t)$ and $V_{d2}(0)$ can be used to extract the OLED voltage.

FIG. 2C is a modified schematic timing diagram of another set of exemplary operation cycles for the pixel 110 shown in FIG. 2A, for taking only a single reading of the drive current and comparing that value with a known reference value. For example, the reference value can be the desired value of the drive current derived by the controller to compensate for degradation of the drive transistor 112 as it ages. The OLED voltage V_{OLED} can be extracted by measuring the difference between the pixel currents when the pixel is programmed with fixed voltages in both methods (being affected by V_{OLED} and not being affected by V_{OLED}). This difference and the current-voltage characteristics of the pixel can then be used to extract V_{OLED} .

During the first cycle 200 of the exemplary timing diagram in FIG. 2C, the select line SEL is high to turn on the switching transistor 118, and the read line RD is low to turn off the read transistor 118. The data line Vdata supplies a voltage Vd2 to node A via the switching transistor 118. During the second cycle 201, SEL is low to turn off the switching transistor 118, and RD is high to turn on the read transistor 119. The monitor line MON supplies a voltage Vref to the node B via the read transistor 118, while a reading of the value of the drive current is taken via the read transistor 119 and the monitor line MON. This read value is compared with the known reference value of the drive current and, if the read value and the reference value of the drive current are different, the cycles 200 and 201 are repeated using an adjusted value of the voltage Vd2. This process is repeated until the read value and the reference value of the drive current are substantially the same, and then the adjusted value of Vd2 can be used to determine V_{OLED} .

FIG. 3 is a circuit diagram of two of the pixels 110a and 110b like those shown in FIG. 2A but modified to share a common monitor line MON, while still permitting independent measurement of the driving current and OLED voltage separately for each pixel. The two pixels 110a and 110b are in the same row but in different columns, and the two columns share the same monitor line MON. Only the pixel selected for measurement is programmed with valid voltages, while the other pixel is programmed to turn off the drive transistor 12 during the measurement cycle. Thus, the drive transistor of one pixel will have no effect on the current measurement in the other pixel.

FIG. 4 illustrates a modified drive system that utilizes a readout circuit 300 that is shared by multiple columns of pixels while still permitting the measurement of the driving current and OLED voltage independently for each of the individual pixels 10. Although only four columns are illustrated in FIG. 4, it will be understood that a typical display contains a much larger number of columns, and they can all use the same readout circuit. Alternatively, multiple readout circuits can be utilized, with each readout circuit still sharing multiple columns, so that the number of readout circuits is significantly less than the number of columns. Only the pixel selected for measurement at any given time is programmed with valid voltages, while all the other pixels sharing the same gate signals are programmed with voltages that cause the respective drive transistors to be off. Consequently, the drive transistors of the other pixels will have no effect on the current measurement being taken of the selected pixel. Also, when the driving current in the selected pixel is used to measure the OLED voltage, the measurement of the OLED voltage is also independent of the drive transistors of the other pixels.

While particular embodiments and applications of the present invention have been illustrated and described, it is to

be understood that the invention is not limited to the precise construction and compositions disclosed herein and that various modifications, changes, and variations can be apparent from the foregoing descriptions without departing from the spirit and scope of the invention as defined in the appended claims.

What is claimed is:

1. A method of determining the current effective voltage V_{OLED} of a light-emitting device in a selected pixel in an array of pixels in a display in which each pixel includes a light-emitting device and a drive transistor for supplying current to said light-emitting device, said method comprising

storing a programming voltage in the selected pixel using the light-emitting device of the selected pixel, the stored programming voltage being a function of the current effective voltage V_{OLED} of said light-emitting device,

supplying current to said light-emitting device via said drive transistor in said selected pixel according to said stored programming voltage, said current being a function of the current effective voltage V_{OLED} of said light-emitting device,

measuring said current, and

extracting the value of the current effective voltage V_{OLED} of said light-emitting device from said current measurement.

2. The method of claim 1 in which said light-emitting devices are OLEDs.

3. The method of claim 1 in which said current is supplied to said light-emitting device via a drive transistor in each pixel.

4. The method of claim 1 in which said current is measured via a read transistor in each pixel.

5. A method of determining the current effective voltage V_{OLED} of a light-emitting device in a selected pixel in an array of pixels in a display in which each pixel includes a light-emitting device and a drive transistor for supplying current to said light-emitting device, said method comprising

supplying a first predetermined programming voltage to said selected pixel to store a first programming voltage in the selected pixel, the stored first programming voltage being independent of the current effective voltage V_{OLED} of said light-emitting device,

supplying a first current to said light-emitting device in said selected pixel according to said stored first programming voltage, said first current being independent of the effective voltage V_{OLED} of said light-emitting device,

measuring said first current,

supplying a second predetermined programming voltage to said selected pixel to store a second programming voltage in the selected pixel using the light-emitting device of the selected pixel, the stored second programming voltage being a function of the current effective voltage V_{OLED} of said light-emitting device,

supplying a second current to said light-emitting device in said selected pixel according to said stored second programming voltage, said second current being a function of the current effective voltage V_{OLED} of said light-emitting device,

measuring said second current, and

extracting the value of the current effective voltage V_{OLED} of said light-emitting device from the difference between said first and second currents and current-voltage characteristics of said selected pixel.

6. A system for determining the current effective voltage V_{OLED} of a light-emitting device of a selected pixel in an array of pixels in a display in which each pixel includes a light-emitting device and a drive transistor for supplying current to the light-emitting device, the system comprising a controller adapted to

store a programming voltage in the selected pixel using the light-emitting device of the selected pixel, the stored programming voltage being a function of the current effective voltage V_{OLED} of said light-emitting device,

supply current to said light-emitting device via said drive transistor in said selected pixel according to said stored programming voltage, said current being a function of the current effective voltage V_{OLED} of said light-emitting device,

measure said current, and

extract the value of the current effective voltage V_{OLED} of said light-emitting device from said current measurement.

20

* * * * *

专利名称(译)	AMOLED显示器的像素电路		
公开(公告)号	US10593263	公开(公告)日	2020-03-17
申请号	US15/888451	申请日	2018-02-05
[标]申请(专利权)人(译)	伊格尼斯创新公司		
申请(专利权)人(译)	IGNIS创新INC.		
当前申请(专利权)人(译)	IGNIS创新INC.		
[标]发明人	AZIZI YASER CHAJI GHOLAMREZA		
发明人	AZIZI, YASER CHAJI, GHOLAMREZA		
IPC分类号	G09G3/3233 H05B33/08 G09G3/3258		
CPC分类号	G09G3/3233 H05B45/14 G09G3/3258 G09G2300/0819 G09G2300/0842 G09G2320/10 G09G2320/0295 G09G2320/0693 G09G2320/048 G09G2320/045		
审查员(译)	XAVIER , ANTONIO		
优先权	15/133318 2017-05-23 US		
其他公开文献	US20180158411A1		
外部链接	Espacenet		

摘要(译)

从当像素被编程时产生的像素中提取所选像素的OLED电压，使得像素电流是OLED电压的函数。提取OLED电压的一种方法是首先以电流不是OLED电压的函数的方式对像素进行编程，然后以电流不是OLED电压的函数的方式进行编程。在后面的阶段中，更改编程电压，以使像素电流与以像素电流不是OLED电压的函数进行编程时的像素电流相同。然后，使用两个编程电压中的差来提取OLED电压。

